

SE 09 - Double Airwalker

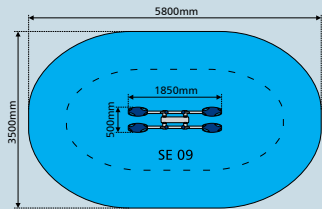

improvement of **coordination**,
endurance and **mobility**

Stand on the foot plates and maintain a firm grip on the handles.
Start walking!





Installation:

The device is delivered completely assembled and is screwed on top of the poured-in place foundation anchor (within the scope of supply). The Installation Guide can be found on www.saysu.de or upon request. Cover the ground anchor with filling material or with plastic covers (accessories).

For your draft we can supply 2D and 3D files.

Picture of the product may differ from original – subject to technical modification.



length:	1850 mm
width:	500 mm
height:	1600 mm
floor space:	0,93 m ²
floor space required:	5800 x 3500 mm
volume:	1,48 m ³
weight:	50 kg
plastic parts:	AW564, AR764 (injection molding) Petilen YY S 0464 (blow moulding) RAL 5002 (ultramarine blue) or  RAL 2008 (bright red orange) 
pipe measurements:	diameter: wall thickness:
	114 mm 3 mm
	60 mm 4 mm
	48 mm 2,6 mm
	27 mm 2,6 mm
metal parts:	stainless steel

certificates: TÜV and GS certified according to PPP 55012:2010 (based on parts of DIN EN 1176, 1177, 957)

user age: children under 14 years only
under surveillance of parents

maximum user weight: 130 kg

safe distance: 1,50 m

drop height: < 0,6 m (possible underground see
DIN 79000:2012-05 Tab. 2 or
installation instructions)

safety system: stopper with damping system

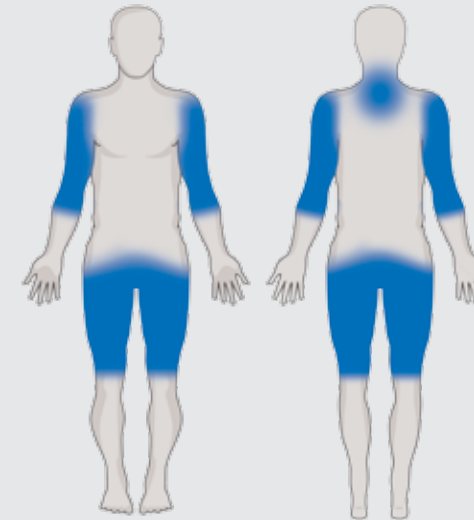

- strength
- endurance
- coordination
- mobility
- relaxation

improvement of coordination, endurance and mobility

function: alternating back and forth movement of legs and arms

effect: improvement of endurance, coordination and balance skills

persons: 2 at the same time, interactive