

SP 14 - One Arm Rotation



stimulates mobility of shoulder girdle, elbow and hand joints

Place your hands on the knobs on the rotating discs and turn them alternating from the left left to right.

For a hand massage, place your palm flat on the disc and turn it.

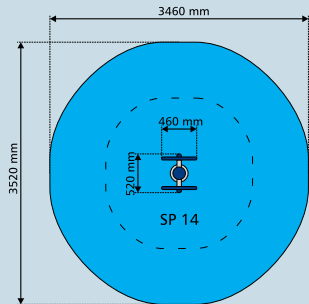

Installation:

The device is delivered completely assembled and is screwed on top of the poured-in place foundation anchor (within the scope of supply). The Installation Guide can be found on www.saysu.de or upon request. Cover the ground anchor with filling material or with plastic covers (accessories).

For your draft we can supply 2D and 3D files.

Picture of the product may differ from original – subject to technical modification.



length:	520 mm	
width:	460 mm	
height:	2000 mm	
floor space:	0,24 m ²	
floor space required:	3520 x 3460 mm	
volume:	0,48 m ³	
weight:	40 kg	
plastic parts:	AW564, AR764 (injection molding) Petilen YY S 0464 (blow moulding) RAL 5002 (ultramarine blue) or  RAL 2008 (bright red orange) 	
pipe measurements:	diameter: 168 mm 60 mm	wall thickness: 4,5 mm 3 mm
metal parts:	steel, zinc phosphated, powder coated RAL 9006 (white aluminium)	

certificates: TÜV and GS according to „DIN 79000:2012-05 Permanently installed outdoor fitness equipment“

user age: children under 14 years only
under surveillance of parents

maximum user weight: 130 kg

safe distance: 1,50 m

drop height: < 0,6 m (possible underground see
DIN 79000:2012-05 Tab. 2 or
installation instructions)

safety system: none required

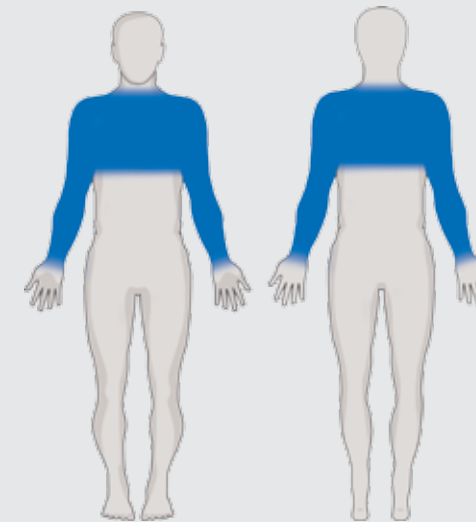

- strength
- endurance
- coordination
- mobility
- relaxation

stimulates **mobility** training of **shoulder girdle, elbow and hand joints**

function: rotation of the discs with the hands

effect: improvement of mobility and coordination, mobilization of the joints, relaxation

persons: 2 at the same time